

This drawing may not be copied, reproduced or made available to third parties in any way whatsoever without or prior written approval.

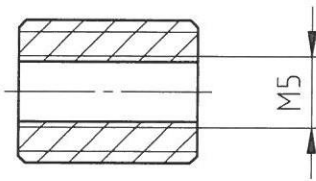

SCHNITT A-A

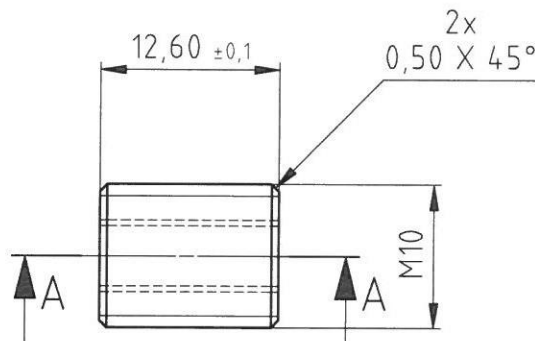

NUR ZUR INFORMATION!

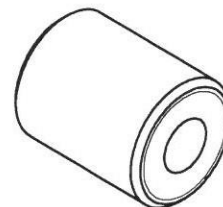

Der Lieferant erkennt mit der Annahme der Zeichnung an, dass er in der Lage ist, das dargestellte Teil nach Zeichnung reproduzierbar in der Serie herzustellen. Durch die gewählten Herstellungsverfahren entstehen keine Beeinträchtigungen an Material und Gefüge, die zur späteren Beeinträchtigung des Bauteils führen können. Mündliche Vereinbarungen darüber hinaus haben keine Gültigkeit. Abweichungen von dieser Regel bedürfen der Schriftform und müssen vom Auftraggeber gegengezeichnet werden.

The supplier acknowledges that, with the acceptance of the drawing, he is in a position to manufacture the illustrated part in accordance with the drawing in reproducible form and series production. Through the selected manufacturing processes no impairments will arise in the material and structure which could subsequently lead to an impairment of the component. Verbal agreements over and above that are not valid. Deviations from this rule must be written and must be signed by the purchaser.

tolerance ISO 2768-mK		part edges DIN 6784		format DIN	article number	material	1.4305
> 0,5-6	±0,1		AFM04 ✓		X8CrNiS18-9		
> 6-30	±0,2		A4	standard	surface		
> 30-120	±0,3		2:1				
> 120-315	±0,4		tolerance ISO 8015	assembly			
> 315-1000	±0,5		roughness serie3 ISO 1302				
				name			
				Gewindebolzen			
				drawing number			index
				AFM04			0.0
				Mdl: AFM04_Gewindebolzen X			
Index	change	date	name	replace for	replace by	sheet	1 of 1